



Page 1 of 9  
Date: June 2011  
Replaces: Form GD108E  
Dated: June 2008

BMC's RT-300 Rough Terrain Crane is a self-propelled crane designed for lifting and material handling applications, with the special features of high maneuverability, high flotation, 4-wheel steer and 4-wheel drive. The basic unit consists of a chassis and hydraulic boom assembly. The chassis includes a frame, four hydraulic outriggers, engine, 6-speed transmission, front steering-driving axle, rear steering-driving axle, fuel tank, oil tank, control station and three-mode full-power steering, all-weather cab, and lighting package. The boom assembly includes a hydraulic-powered rotating turret, hydraulic telescopic boom, hydraulic boom elevation and a hydraulic-powered planetary gear winch, sheave block and downhaul weight. A Rated Capacity Limiter (RCL) is standard.

**RT-300-2F:**

4-section hydraulically extended boom with capacity of 30,000 pounds (13,600 kg) at 10 feet (3.05 m). Horizontal reach of 60 feet (18.3 m) and maximum height of 70 feet (21.3 m).

**General:****Length:**

Overall 29 feet 10 inches (9.09 m)  
Chassis 16 feet 10 inches (5.13 m)

**Width** 8 feet 4 inches (2.54 m)

**Height** 11 feet 2 inches (3.40 m)

**Wheelbase** 9 feet 5 inches (2.87 m)

**Ground Clearance (Chassis)** 15 inches (38 cm)

**Angle of Approach** 24 degrees

**Angle of Departure** 22 degrees

**Turning Radius 4-Wheel Steer: (Min.)**

Outside Tire Centerline Radius 15 feet 7 inches (4.75 m)

Vehicle Clearance Circle Diameter 35 feet 2 inches (10.72 m)

**Road Speed** 23 miles per hour (37 km/h)

**Gradeability (Calculated)** 70 percent grade (35 degrees)

(Wheels may spin before values are reached)

**Grade Limit (Calculated)** 20 percent grade (11 degrees)

(Wheels may spin before values are reached)

**Outriggers:****Spread:**

Pin-to-Pin of Shoe 12 feet 9 inches (3.89 m)

Overall Width 14 feet 5 inches (4.39 m)

Ground Penetration 5 inches (13 cm)

**Weight For Basic Machine:**

Total 45,330 pounds (20,560 kg)

Front Axle 22,930 pounds (10,400 kg)

Rear Axle 22,400 pounds (10,160 kg)

**Drawbar Pull:** 30,000 pounds (13,600 kg)

**Hoist Pull (Bare Drum)** 13,100 pounds (5,940 kg)

**General: (Cont'd)**

<u>Boom Functions</u>	<u>Boom Movement</u>	<u>Boom Speeds</u>
Rotation	Continuous	3.5 rpm
Elevation	0-70 degrees	22 Seconds
Extension	40 feet (12.19 m)	25 Seconds
<b>Hoist Line Speed</b>	240 ft/min (73 m/min)	
<b>Maximum Boom Height:</b>		
Without Boom Extension	70 feet 0 inches (21.34 m)	
With Boom Extension	87 feet 11 inches (26.80 m)	
<b>Horizontal Reach:</b>		
Without Boom Extension	60 feet 0 inches (18.29 m)	
With Boom Extension	80 feet 0 inches (24.38 m)	

**Engine:**

**Standard:**

**Cummins – QSB4.5 Turbo:**

Cummins Model QSB4.5 diesel engine, turbocharged, charge air cooled, four cylinder, 4.5 liter (275 CID). U.S. EPA Tier 3 certified. Bore 4.21 inches (10.7 cm), stroke 4.88 inches (12.4 cm). Rated 160 hp (119 kw) at 2,500 rpm. 460 foot pounds (624 Nm) maximum torque at 1,500 rpm. 95 amp alternator. Oil capacity, 11.6 quarts (11 L). Coolant capacity, 14 quarts (13.2 L). Electronic controls for three engine speeds during crane operation – 640, 1200 or 1840 rpm. Protection system shuts down engine when coolant is too hot or oil pressure is too low. Charge air cooler, grid heater and engine block heater which plugs into 120 volt AC extension cord are included.

**Fuel Tank:**

50 gallon (190 L) capacity.

**Transmission:**

**Standard:**

Funk Manufacturing Co. Model 2000 powershift transmission with 6 forward speeds and 3 reverse. Provides full powershifts at maximum engine speed in all gears. All shifting is done with a single-lever electrical control in the operator compartment. The transmission includes an automatic rear axle disconnect for two-wheel drive in speeds 4, 5 and 6 in forward and speed 3 in reverse. The other speeds are four-wheel drive. A torque converter with a stall torque ratio of 2.640:1 attaches directly to engine flywheel to drive transmission. Equipped with oil cooler and filter.

**Forward gear ratios and speeds:**

<u>GEAR RATIO</u>	<u>SPEED</u>
1st 8.20	2.7 mph (4.3 km/h)
2nd 4.64	4.8 mph (7.7 km/h)
3rd 3.53	6.3 mph (10.1 km/h)
4th 2.00	11.2 mph (18.0 km/h)
5th 1.41	15.8 mph (25.4 km/h)
6th 0.80	24.0 mph (38.6 km/h)

**Reverse gear ratios and speeds:**

<u>GEAR RATIO</u>	<u>SPEED</u>
1st 8.20	2.7 mph (4.3 km/h)
2nd 3.53	6.3 mph (10.1 km/h)
3rd 1.41	15.8 mph (25.4 km/h)

**Front Axle:**

**Standard:**

AxleTech planetary driving-steering axle with 16.42 to 1 ratio. Rigid mounted on front. Axle has limited-slip differential.

**Rear Axle:**

**Standard:**

AxleTech planetary driving-steering axle with 16.42 to 1 ratio. Rear axle is mounted with rubber elements to allow oscillation. Axle is not available with no-spin or limited-slip differential.

**Brakes:**

**Standard:**

Four-wheel hydraulic with hydraulic booster. 17 inch (43 cm) x 4 inch (10 cm) brake at each wheel. Spring-applied and hydraulically released, disc-type parking brake on transmission.

**Steering****Standard:**

Hydraulic steering unit with two 3.5 inch (8.9 cm) cylinders attached to each axle. Allows limited steering when engine is not running. A switch on the control panel is used to select front-wheel steering, 4-wheel steering or crab steering. Electronic sensors and control box automatically align the steering when a new mode is selected. Steering wheel and electronically controlled selector valve control 3-mode steering: crab, round and 2-wheel front axle steering.

**Tires:****Standard:**

17.5 x 25, 20-ply rating, mud lug.

**Optional Tires:****Spare Wheel and Tire, Standard Size:**

Extra wheel with 17.5 x 25, 20-ply rating tire mounted, ready for service. Net Weight: 530 pounds (240 kg)

**Chassis:****Standard:****Engine Covers:**

Flip-up side covers.

**Steps:**

Grip-strut steps and grab bars provide easy two-step access to operator's compartment.

**Outriggers:**

Four independently controlled outriggers of swing-down design. Hydraulic cylinders are equipped with direct connected holding valves. Foot pad dimensions: 20 inches (51 cm) by 16 inches (41 cm).

**Sheave Block and Downhaul Weight Storage:**

Tray on left-hand side behind hydraulic tank for storing sheave block and downhaul weight for single-part line. Sheave block and downhaul weight are securely retained by chain and locking device.

**Tie Downs:**

Four holes (two front, two rear) that provide tie down locations for truck transport.

**Optional Chassis Accessories:****Fenders:**

Four bolt on steel fenders over tires. Designed to reduce mud and rocks thrown from wheels in off-road applications. Also acts as platform for entrance and egress to cab. Includes rubber mud flaps and additional steps.  
Net Weight: 750 lbs (340 kg)

**Auxiliary Front Winch:\***

Planetary gear winch, mounted on front outrigger frame, with single-lever control on the operator console. Hydraulic powered to provide bare drum line pull of 14,700 lbs (6670 kg) and 68 ft/min (21m/min) line speed. Winch drum is 9.75 inches (24.8 cm) diameter by 13 inches (33.0 cm) long. Includes 125 feet (38.1 m) of 9/16 inch (14.3 mm) diameter 6x36-EIP-IWRC wire rope. Also includes wedge socket and 10,000 lb (4540 kg) hook. A pulling eye is provided on the outrigger frame below the winch for two parting the line with a sheave block (sheave block not included). Winch is mounted with four bolts and connected by quick-disconnect couplings for easy mounting and removal. Net Weight: 480 lbs (220 kg) (\*Requires optional Operator Guard)

**Lifting Eyes:**

Consists of four eyes on chassis and turntable so slings can be attached for lifting crane. Net Weight: 40 pounds (18 kg)

**Towing Eyes:**

Consists of four eyes, two on front and two on rear, for towing. Net Weight: 40 pounds (18 kg)

**Pintle Hook Front:**

T-60-AOL Holland pintle hook mounted on front outrigger frame member, rated for 30,000 pounds (13,600 kg) trailer weight. Not available with Auxiliary Front Winch. Net Weight: 15 pounds (6.8 kg)

**Pintle Hook Rear:**

T-60-AOL Holland pintle hook mounted on rear frame member, rated for 30,000 pounds (13,600 kg) trailer weight. Net Weight: 15 pounds (6.8 kg)

**Operator Compartment:****Standard:**

Operator control station provides one-position access to all chassis and crane controls.

**Mirrors:**

A 7x16 (18cm x 41 cm) mirror on each side of the operator's compartment provides visibility behind the crane.

**All Weather Cab:**

Consists of rigid-mounted canopy section and two removable hinged doors with safety glass. Rugged canopy structure with laminated glass front and top. Doors are equipped with keyed locks to protect operator's compartment. Includes heater with two-speed fan, interior light, electric windshield wiper, 12-volt power outlet and a variable-speed electric defroster fan.

**Operator Compartment Options:****Window Wiper - Top Window:**

12-volt electric wiper on top window operated with its own switch.

**Operator Guard:**

Tubular steel weldment with heavy expanded steel mesh top and grille front section. Guard will tilt to allow cab windows to be cleaned. Required with Front Auxiliary Winch. Net Weight: 140 pounds (64 kg)

**Operator's Suspension Seat - Cloth:**

Full-suspension with adjustments for height, tilt, fore-aft, operator weight and with armrest angle adjustment.

**Operator's Suspension Seat - Vinyl:**

Full-suspension with adjustments for height, tilt, fore-aft, operator weight and with armrest angle adjustment.

**Air Conditioning:**

Provides factory system using R134a refrigerant. Compact AC unit mounted in operator area, fan cooled condenser mounted on hood and belt driven compressor with magnetic clutch driven by engine.

Net Weight: 125 pounds (57 kg)

**Floor Mats:**

Removable rubber mats in cab.

**Electrical System:****Standard****Battery:**

12 Volt, Group 31, 950 CCA battery.

**Instrument Group:**

Located at operator's station and includes fuel gauge, transmission oil temperature gauge, voltmeter, oil pressure, water temperature and hydraulic oil temperature gauges. Key switch and horn button on instrument panel. Hour-meter records only during actual engine operation. Also included are indicator lights for two-wheel drive, four-wheel drive and parking brake.

**Lighting Kit:**

Two modular, dual-beam headlights with turn signal lights. Taillights with brake and turn signal lights. Back-up lights. Turn signal and flasher switch. Lights installed in back of instrument gauges for night time operation. High-beam indicator lamp.

**Back-Up Alarm:**

Provides pulsating sound from 97 dB alarm when ignition is on and transmission is in reverse.

**Outrigger Alarm System:**

112 dB alarm with alternating two-tone sound is actuated by a switch when the "outrigger down" controls are operated.

**Optional Electrical Accessories:****Strobe Light:**

Yellow strobe light mounted on top of engine hood for high visibility. Flashes 60-120 times per minute. Strobe draws only one-half amp. Includes switch in operator compartment.

**Boom Work Lights:**

Two halogen work lights, one on left side of boom to light boom tip and one on the turret to light ground under boom

tip. Includes switch in operator compartment. Net Weight: 10 pounds (4.5 kg)

**Hydraulic System:****Standard:**

Triple gear pump, mounted on and driven by the main transmission, delivers 14, 28 and 40 gpm (53, 106 and 151 L/min) at 3,000 psi (207 bar) and 2,500 rpm engine speed. System protected by relief valves, 100 mesh suction-line strainer and 10 micron return-line filter.

**Hydraulic Reservoir:**

70 gallon (265 L) capacity, equipped with 40 micron breather filter on top and oil level gauge on side.

**Boom:****Standard:**

High strength steel construction, equipped with bearing pads for efficient support and extension. Double-acting hydraulic cylinders extend and retract the second and third boom sections. Double runs of high strength leaf chain extend and retract the fourth section. The second stage extends first and retracts last, controlled by sequencing valves in the boom. The third and fourth sections extend and retract together proportionally, controlled by chains. The extension system is equipped with a holding valve. Twin, double-acting hydraulic cylinders control the boom elevation and are equipped with direct connected holding valves. Boom angle indicator is provided on left side of the boom. Boom tip sheaves are provided for four-part line.

**Boom Hoist:****Standard:**

Turret-mounted, planetary gear winch, is hydraulically powered to provide a bare-drum line pull of 13,100 pounds (5940 kg) and a speed of 185 feet per minute (56m/min). Line speed of the fourth layer on the drum is 240 feet per minute (73 m/min). Drum diameter is 9.75 inches (24.8 cm), length is 16 inches (40.6 cm). Includes 350 feet (107 m) of 9/16 inch (14.3 mm) wire rope, 6 X 36- EIP-RRL-IWRC, 26,600 pound (118 kN) breaking strength.

**Downhaul Weight and Hook:****Standard:**

Downhaul weight and 10,000 pound (4540 kg) swivel hook to use with existing wedge socket on 9/16 inch (14.3 mm) load line. Specially designed to work with the anti-two-block system and to clamp the dead end of the rope. )

**Boom Rotation:****Standard:**

Heavy-duty ball bearing with external teeth supports boom. Rotation is by hydraulic motor and compound planetary gear drive. A spring-applied hydraulically released brake and an over-running load valve are provided. Hydraulic centerpost and electric slip rings allow continuous rotation.

**Anti-Two-Block Device:****Standard:**

Designed to prevent damage to hoist rope and/or machine components from accidentally pulling sheave block or downhaul weight against boom tip. Consists of pivot arm at boom tip that is moved upward by sheave block or downhaul weight as hook approaches boom tip. Pivot arm actuates electric switch that is connected by cable reel to solenoid dump valve in hydraulic circuit. This valve will dump the **HOIST RAISE, TELESCOPE EXTEND, BOOM LOWER** circuits. No other circuits are affected. These circuits are returned to normal operation by lowering the load to a safe resting place with hoist or by retracting or raising boom to a shorter load radius. Key-operated, momentary override switch located under dashboard.

**Rated Capacity Limiter:****Standard:**

Operator's aid that warns operator of impending overload with audible and visual signals. Has read-outs for load, boom angle, boom length and load radius. In the event of an overload, dumps the following boom functions: **HOIST RAISE, TELESCOPE EXTEND, BOOM LOWER**. These circuits are returned to normal by lowering load to a safe resting place with hoist or by retracting or raising boom to a shorter load radius. There is also an override button on the RCL control panel and an override switch under the dashboard.

**Sheave Block:****Standard:**

Double sheave block for four-part-line requirements. 12-inch (30.5 cm) O.D. sheaves for 9/16 inch (14.3 mm) diameter wire rope. Swivel hook with safety latch. Includes bar on top to actuate trip arm of anti-two-block device. 440-pound (200 kg) weight provides positive overhaul.

**Optional Boom Attachments:**

**Boom Extension - 20 Ft. (6.1 m), Offset:**

Provides 20 feet (6.1 m) of additional length for lifting loads with load line. May be set at 0 (in-line), 15 or 30 degrees offset. Swing-away boom extension may be stowed alongside base boom section when not in use. Tip sheave, knuckle sheave, attaching brackets and pins included. When boom extension is in the stowed position, the crane payload must be reduced by 500 pounds (225 kg). Includes anti-two-block system. Net Weight: 770 pounds (350 kg)

**Specifications subject to change without notice.**

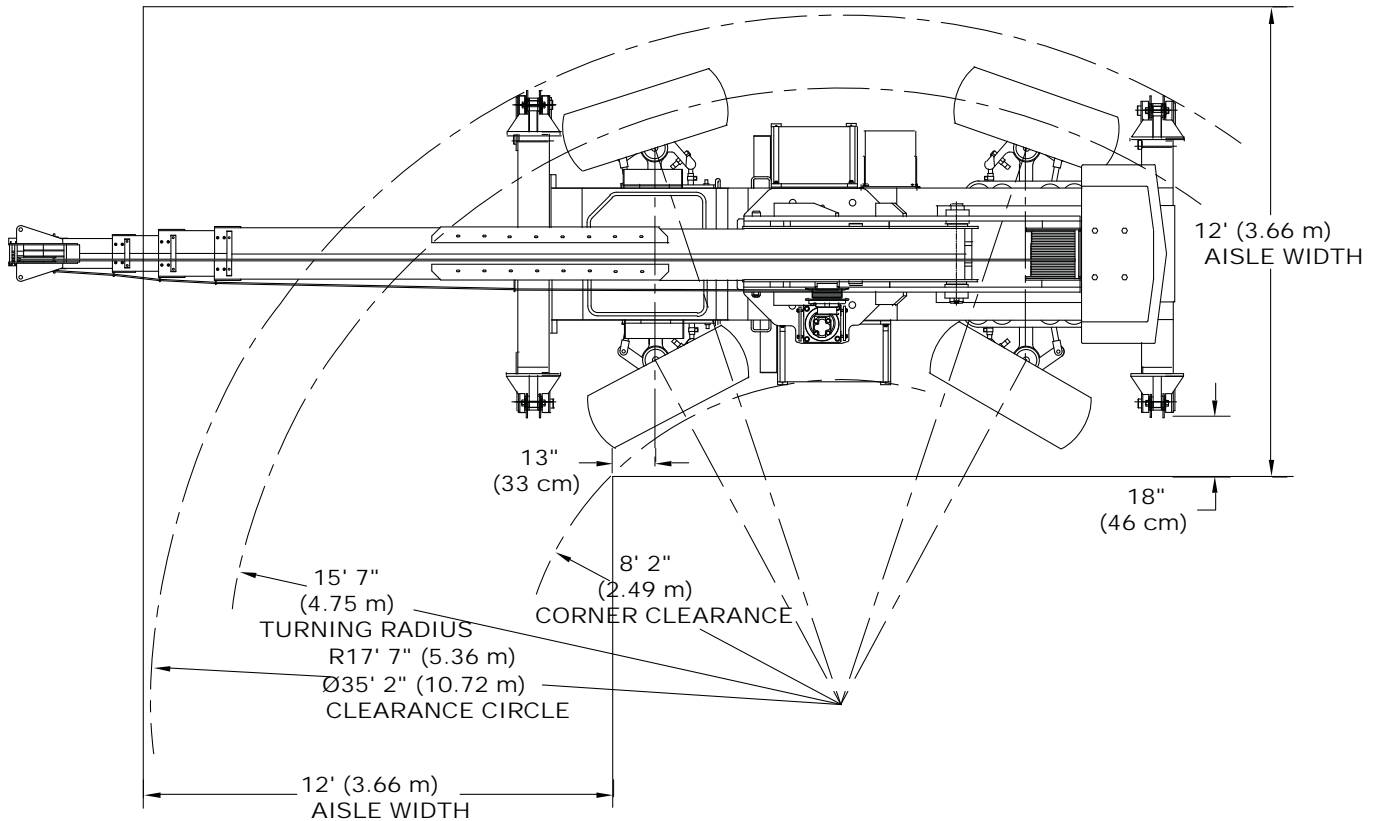

Should you require an option or special equipment not listed please consult your dealer salesperson or BMC®.

**BRODERSON**  
 Manufacturing Corp.  
 14741 West 106th Street  
 Lenexa, KS 66215 USA

Tel (913) 888-0606  
 Fax (913) 888-8431  
 www.bmccranes.com

Dimensions and values shown are for reference purposes only.  
 Specifications subject to change.



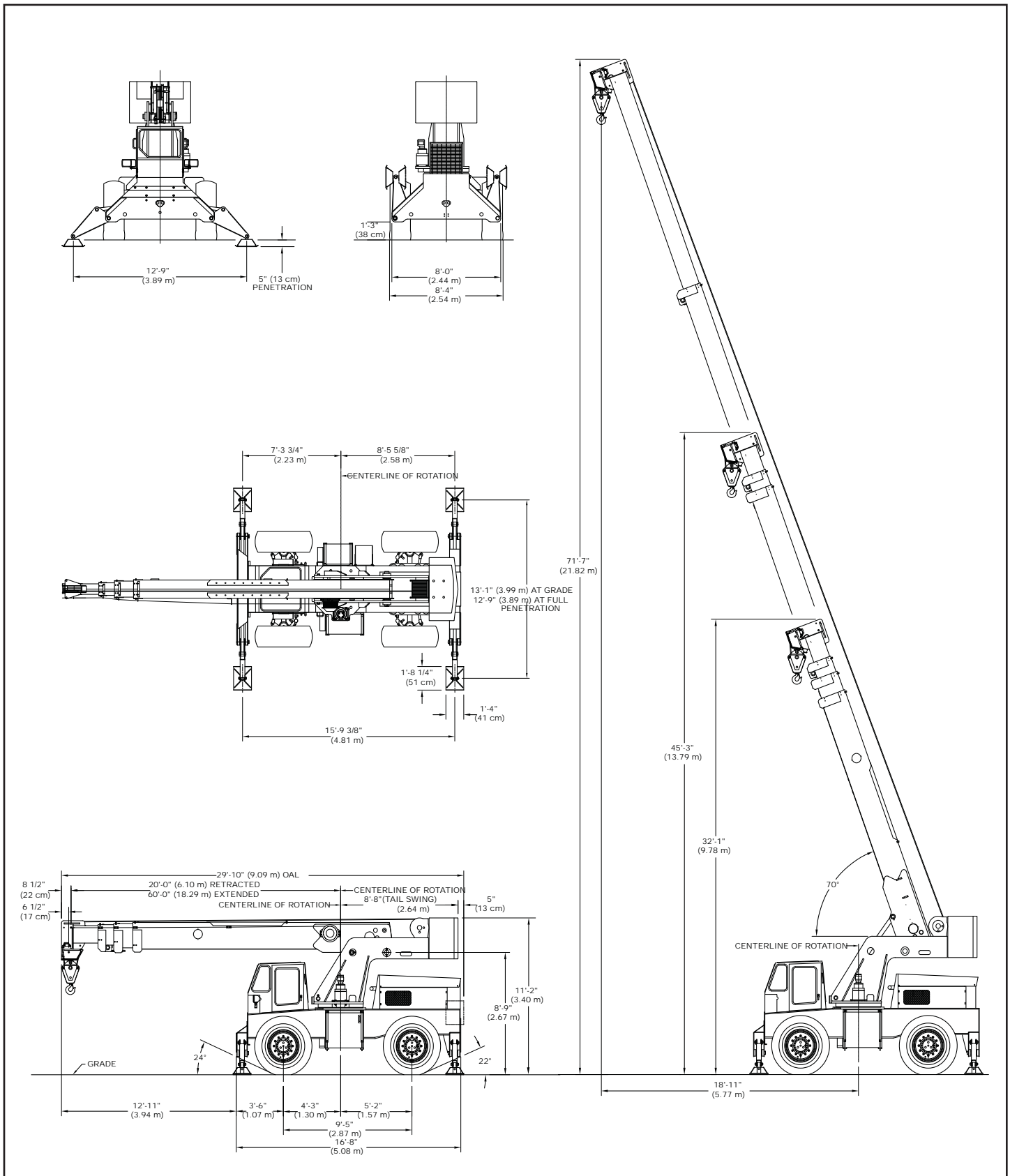

LOAD RADIUS IS THE HORIZONTAL DISTANCE FROM CENTER OF ROTATION TO THE VERTICAL LOAD LINE WITH LOAD APPLIED.

LOAD HOOKS, DOWNHILL WEIGHTS, HOOK BLOCKS AND OTHER LOAD HANDLING DEVICES SHALL BE CONSIDERED PART OF THE LOAD EXCEPT FOR HOIST ROPE.

BOOM EXTENSION DEDUCT 500 LBS. WHEN STOWED ON BASE BOOM.

CAPACITIES ON OUTRIGGERS ARE 5% OF TIPPING LOADS. CAPACITIES ON RUBBER ARE 75% OF TIPPING LOADS. CAPACITIES BELOW BOLD LINES ARE LIMITED BY TIPPING. OTHER CAPACITIES ARE LIMITED BY STRUCTURAL OR HYDRAULIC CAPACITY.

THE BOOMS ON THIS UNIT ARE ALL STEEL AND HAVE NO LINE VOLTAGE RATING - NO ELECTRICAL INSULATION VALUE.

MAXIMUM HYDRAULIC PRESSURE - 3000 PSI.

OPERATION: UNDERSTAND OWNERS MANUAL BEFORE OPERATING.

1. CHECK LEVEL OF HYDRAULIC OIL AND ENGINE OIL DAILY.

2. CHECK UNIT FOR VISIBLE DEFECTS AND LOOSE PARTS DAILY.

3. OUTRIGGERS MUST ALL BE SET ON SOLID SURFACE.

5. AVOID QUICK STARTS AND STOPS WITH HYDRAULIC CONTROLS.

PICK AND CARRY ON RUBBER CAPACITIES ARE FOR SMOOTH, LEVEL PAVED SURFACE. FOR UNPAVED SURFACE REDUCE CAPACITY BY AT LEAST 25%.

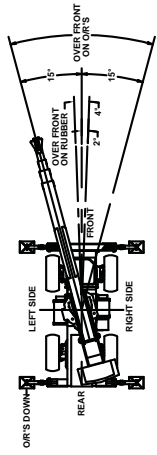

THE LOAD HOIST LINE ON THIS UNIT MUST BE 3/16" DIA. 6 X 36-FIP-R1-INRVC WIRE ROPE (OR EQUIVALENT) WITH A MINIMUM BREAKING STRENGTH OF 33,600 LBS.

TIRE PRESSURE 100 PSI FOR 17.5-25 20PR.

LOAD RADIUS FEET	CAPACITIES APPLY TO OPERATION ON FIRM LEVEL SURFACE		MAIN BOOM CAPACITIES IN POUNDS	
	360° ROTATION ON RUBBER	ROTATION ON OUTRIGGERS	ON RUBBER	ON OUTRIGGERS
10	18500	30000	25300	30000
12	13500	28500	22500	28500
14	10400	25900	17600	25900
16	8200	23000	14000	23000
18	6500	19500	11400	19500
20	5500	16500	9400	17000
22	4500	14200	7900	15000
24	3700	12100	6800	13300
26	3100	10500	5700	11900
28	2500	9100	4800	10600
30	2000	7900	4200	9600
32	1600	6900	3600	8600
34	1400	6300	3200	8000
36	1200	5700	2900	7500
38	900	5200	2600	6900
40	800	4800	2400	6500
44	600	4100	1900	5600
48	500	3500	1600	4900
52	400	3100	1300	4200
56	300	2700	1000	3700
60	250	2400	800	3300
64	200	2100	650	2900
68	175	1900	550	2600
72	150	1700	450	2300
76	130	1500	350	2000
80	100	1300	250	1700

DO NOT POSITION BOOM AT LOAD RADII WHERE NO LOAD CAPACITIES ARE SHOWN.

BOOM EXTENSION IN FEET	20-FOOT BOOM EXTENSION CAPACITIES	
	ON RUBBER	ON OUTRIGGERS
0°	2300	2400
15°	2300	2400
30°	2300	2400
45°	2300	2400
60°	2300	2400
75°	2300	2400
90°	2300	2400

CAUTION: BOOM EXTENSION LOADS MUST NOT EXCEED MAIN BOOM CAPACITY.

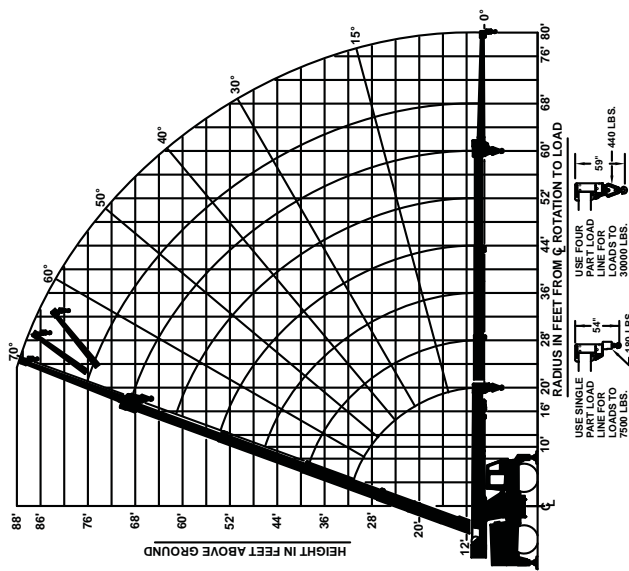



# Metric

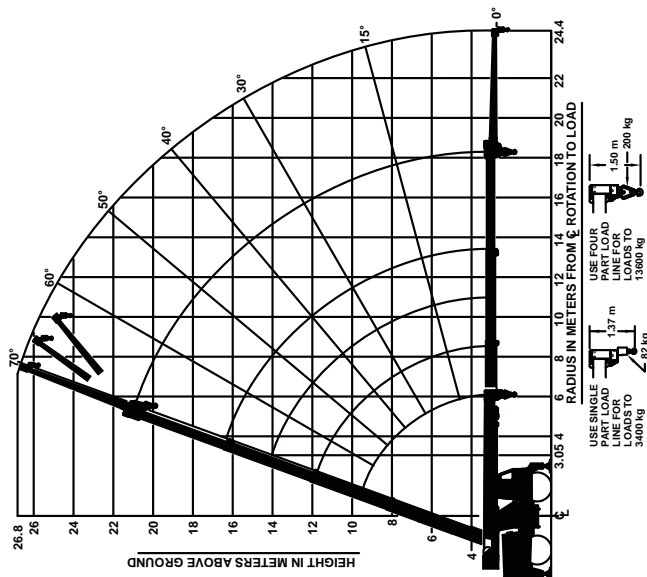

CAPACITIES APPLY TO OPERATION ON FIRM LEVEL SURFACE

LOAD RADIUS METERS	MAIN BOOM OR EXTENSION CAPACITIES IN KILOGRAMS	
	ON RUBBER	ON OUTRIGGERS
3.05	8300	13800
3.5	5240	12150
4.0	4220	11150
4.5	3600	9320
5.0	3020	8820
5.5	2570	7850
6.0	1850	5930
7.0	1370	4680
8.0	960	3700
9.0	690	3020
10.0	540	2570
11.0	420	2230
12.0	370	1960
13.0	300	1860
14.0	270	1720
15.0	230	1530
16.0	190	1380
17.0	160	1220
18.0	140	1080
19.0	120	940
20.0	100	840
22.0	70	670
24.0	40	450

DO NOT POSITION BOOM AT LOAD RADI WHERE NO LOAD CAPACITIES ARE SHOWN.

BOOM EXTENSION OFFSET ANGLE	6.1 m BOOM EXTENSION CAPACITIES					
	0°	15°	30°	40°	50°	70°
0°	1040	1090	1220	1400	1680	2170
15°	1040	1090	1180	1310	1540	1860
30°	1040	1090	1090	1130	1220	1400

CAUTION: BOOM EXTENSION LOADS MUST NOT EXCEED MAIN BOOM CAPACITY.

LOAD RADIUS IS THE HORIZONTAL DISTANCE FROM CENTER OF ROTATION TO THE VERTICAL LOAD LINE WITH LOAD APPLIED. LOAD HOOKS, DOWNHAUL WEIGHTS, HOOK BLOCKS AND OTHER LOAD HANDLING DEVICES SHALL BE CONSIDERED PART OF THE LOAD EXCEPT FOR HOIST ROPE.

BOOM EXTENSION DEDUCT: 225 kg WHEN STOWED ON BASE BOOM.

CAPACITIES ON OUTRIGGERS ARE 85% OF TIPPING LOADS - ON RUBBER. 75% OF TIPPING CAPACITIES BELOW BOLD LINES ARE LIMITED BY TIPPING. OTHER CAPACITIES ARE LIMITED BY STRUCTURAL OR HYDRAULIC CAPACITY.

THE BOOMS ON THIS UNIT ARE ALL STEEL AND HAVE NO LINE VOLTAGE RATING. - NO ELECTRICAL INSULATION VALUE.

MAXIMUM HYDRAULIC PRESSURE - 207 bar

- OPERATION: UNDERSTAND OWNERS MANUAL BEFORE OPERATING.
- CHECK LEVEL OF HYDRAULIC OIL AND ENGINE OIL DAILY.
  - CHECK UNIT FOR VISIBLE DEFECTS AND LOOSE PARTS DAILY.
  - OUTRIGGERS MUST ALL BE SET ON SOLID SURFACE.
  - AVOID QUICK STARTS AND STOPS WITH HYDRAULIC CONTROLS.
  - PICK AND CARRY ON RUBBER CAPACITIES ARE FOR SMOOTH, LEVEL PAVED SURFACE. FOR UNPAVED SURFACE REDUCE CAPACITY BY AT LEAST 25%.

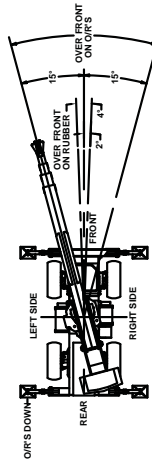

THE LOAD HOIST LINE ON THIS UNIT MUST BE 14.3 mm DIA. 5 X 36 EIP IWRC WIRE ROPE (OR EQUIVALENT) WITH A MINIMUM BREAKING STRENGTH OF 120 kN. TIRE PRESSURE 689 kPa FOR 17.5-25 20PR.

# Metric